

120S CAST IRON SWING CHECK VALVE

- ❖ Iron Body, Threaded Ends ❖ Bronze Seat & Resilient Disc ❖ Bolted Cover
 - ❖ Class 125 ❖ Suitable For Vertical & Horizontal Installation
 - ❖ Full Waterway ❖ Hibuild Epoxy Coating Inside and Outside
- ## 200 PSI NON-SHOCK COLD WOG

Applications: Irrigation, Potable Water, Turf, Golf Course, Water Distribution, Pump Station

Conforms to MSS-SP-71
Threaded Ends Conform to ANSI/ASME B1.20.1
ISO-9002

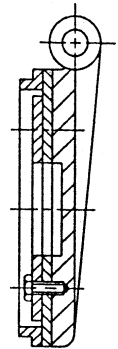
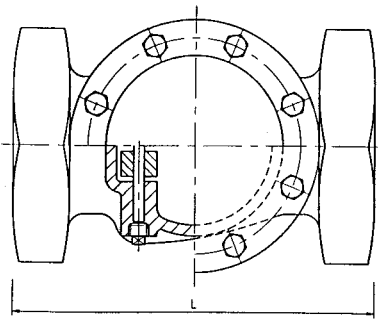
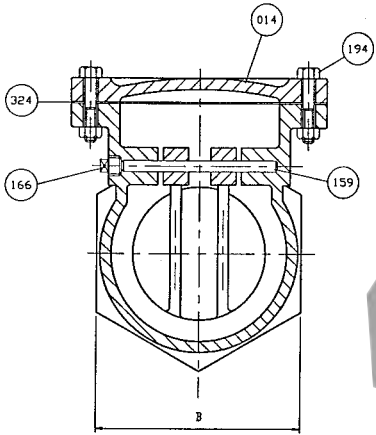
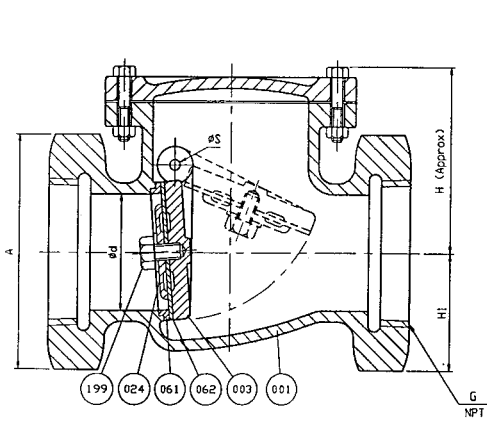

For Size 8"

DIMENSIONS & WEIGHTS

SIZE INCH	L	A	B	G	H	H1	APPROX. WT. LBS.
2"	7.0	3.63	3.16	2.0	4.19	1.81	14
2-1/2"	7.5	4.31	3.75	2.5	4.94	2.16	18
3"	9.0	5.00	4.31	3.0	5.94	2.50	27
4"	10.5	7.06	6.13	4.0	6.69	3.53	53
5"	11.3	7.31	6.88	5.0	7.31	3.97	69
6"	12.5	9.44	8.19	6.0	7.69	4.72	99
8"	16.0	11.75	10.25	8.0	9.25	5.88	205

MATERIAL SPECIFICATIONS

NO.	PART	MATERIAL	ASTM DESIGNATION
001	Body	Cast Iron	A 126 Class B
003	Disc	Cast Iron	A 126 Class B
014	Cover	Cast Iron	A 126 Class B
024	Seat Holder	Cast Iron	A 126 Class B
061	Body Seat Ring	Bronze	B 62
062	Disc Seat Ring	Rubber (BUNA-N)	D 2000 AA 7008
159	Hinge Pin	Stainless Steel	A 276 Type 304
166	Plug	Malleable Iron	A 47
194	Cover Bolt & Nut	Steel	A307 Grade B
199	Seat Holder Bolt	Stainless Steel	A 276 Type 304
324	Cover Gasket	Rubber (BUNA-N)	D 2000 AA 7008

Product Spec Sheet



BREWSTER: TEL:800-431-2082 FAX: 800-640-2252 HOUSTON: TEL: 800-935-5456 FAX:800-683-4247