



ELECTRONICS

Redi-Flo3

DATA BOOK

COMMUNICATIONS



P E R F O R M A N C E

Grundfos Environmental Products Division

GRUNDFOS[®]



Table of Contents

Features and Benefits	pages 2-3
Applications	pages 4-5
Communications	pages 6-9
Performance and Technical Data	pages 10-17
Accessories	page 18

Features and Benefits

Redi-Flo3 Submersible Pumps

Redi-Flo3 pumps are suitable for both continuous and intermittent operation for a variety of environmental applications including:

- Remediation
- Pollution Recovery
- Leachate Recovery
- Dewatering
- Tank Applications

Redi-Flo3 pumps offer the following features:

- Dry-Run Protection
- High Efficiency Pump End and Motor
- Excellent Wear and Solids Resistance
- High Starting Torque
- Protection Against Up-Thrust
- Soft-Start
- Over- and Under-Voltage Protection
- Overload Protection
- Over-temperature Protection
- Variable Speed
- Electronic Control and Communication

Redi-Flo3 pumps incorporate a totally new motor design. With the use of permanent-magnet technology within the motor, Redi-Flo3 pumps deliver unmatched performance. The combination of permanent-magnet motors and Grundfos' own micro frequency converter, we are now able to communicate with the pump in ways never before possible. Just a few of the features that come out of this combination are constant level control, soft-start and integrated dry-run protection. These are just a few of the many features that Redi-Flo3 pumps can offer.

Redi-Flo3 pumps use the Grundfos "Smart Motor". This permanent-magnet motor is single phase and with a 2-wire design makes installation easy. The combination of integrated microelectronics in the pump and the optional status box and R100 at the surface allows communication with the pump through standard electrical motor leads. No additional wires are required. This feature provides the direct use of multiple sensors, digital input and relays without adding extra electronics and costs.

The surface status box allows communication with the "Smart Motor" through the R100 infrared remote control unit or CU300 PC Software Tool. This gives you the ability to monitor and setup your pumping system to meet the specific needs of your application.

The Redi-Flo3 can operate without the status control box much like a traditional submersible electric pump. Some communication and program functions will not be available in this configuration.

Pump and Motor Range

Product	Description
Redi-Flo3 Pump End	5,10,15,22,30, GPM
MSE3NE Motor	Single Phase 1/3 - 1.5 Hp

Dry-Run Protection

The Redi-Flo3 incorporates integrated Dry-Run protection. When the fluid level falls below the inlet of the pump, the pump automatically shuts off. After a programmable period of time, the pump automatically starts up again.

High Motor Efficiency

Redi-Flo3 motors are based on a permanent magnet rotor, which produce high efficiency within a wide load range. The high and flat efficiency curve of the Permanent-Magnet (PM) motor allows for coverage of a wide power range with the same motor as compared to conventional submersible AC motors. For Redi-Flo3 pumps, this means only three motors to cover the horsepower range from 1/3 to 1.5Hp.

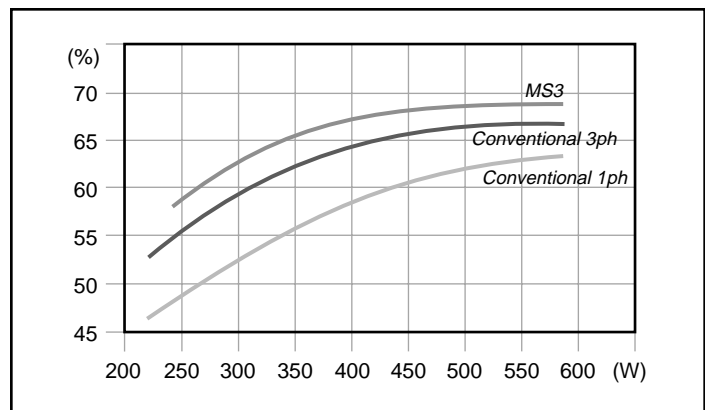

High Pump Efficiency

The pump end components are made from Polyvinylidene Fluoride (PVDF). The pumps are designed to deliver at peak efficiency levels. Because of high pump efficiencies, overall power consumption will be reduced.

Excellent Wear Resistance

Redi-Flo3 pump design uses “floating” impellers. Each impeller has its own tungsten carbide/ceramic bearing. This design and the environmental quality of materials make this pump very wear resistant especially in high solids conditions.

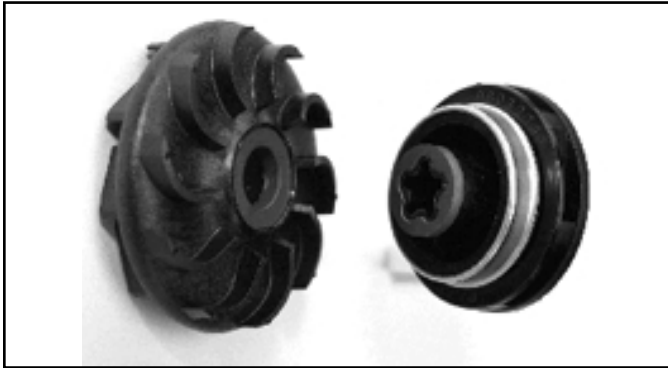

Protection Against Up-Thrust

During start-up many pumps start in an up-thrust condition. To prevent damage caused by up-thrust, a top bearing has been placed in the motor to protect both the pump and the motor against up-thrust.

Soft-Start

Redi-Flo3 have a soft-start feature possible because of the integrated electronics. Soft-start reduces the starting current and gives the pump a smooth and steady acceleration.

High Starting Torque

Because of the permanent-magnet motor, the Redi-Flo3 pumps have excellent starting capabilities. The high locked rotor torque produced by the PM motor provides a starting torque that is 1.5 times greater than conventional submersible pump motors. Even if the voltage is low, the PM motor will still maintain a high starting torque.

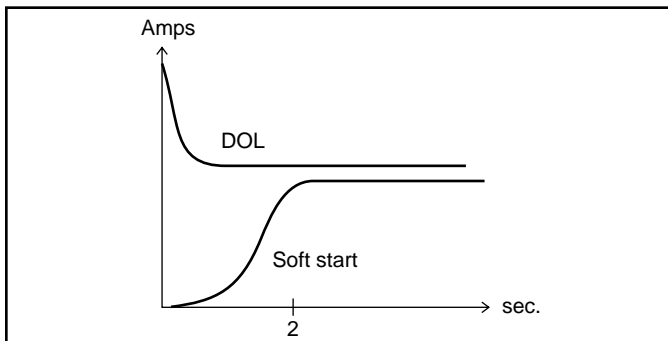

Overvoltage and Undervoltage Protection

Overvoltage and undervoltage may occur at any time, especially if you have an unstable voltage supply. The integrated protection in the Redi-Flo3 motor protects itself when voltage falls outside of permissible voltage range. The 230V pump motor will cut out if voltage falls below 150V or above 280V. The motor will automatically start when the voltage is within the permissible range. It is not necessary to have additional voltage protection.

Overload Protection

When the pump load rises above the maximum amp level, the motor will automatically compensate and reduce the speed to maintain its maximum amp level. If the speed drops to 65% of the nominal speed, the motor will shut off.

Overtemperature Protection

Permanent-magnet motors emit very little heat because of their high efficiency. Redi-Flo3 motors are designed with an internal circulation system to effectively cool all the internal components.

As extra protection, the electronic unit also has a built-in temperature sensor. When the temperature rises too high, the motor will automatically shut-off; when the temperature drops the motor will automatically restart.

Variable Speed

The Redi-Flo3 “Smart” motor enables continuous variable speed control within 65%-100% (7000-10,700 rpm). The pump can be set to operate at any duty point in the range between 65% and 100% of the pumps performance curve. The pump can be adapted to any specific requirement. The variable speed control requires the status box and R100 or potentiometer.

Installation

Redi-Flo3 pumps can be installed vertically or horizontally (Note: the pump must not fall below the horizontal level in relation to the motor). For horizontal installations, a flow sleeve is recommended to ensure sufficient flow past the motor to provide proper cooling and prevent the unit from being buried in sand or silt.

Service

The modular design of the Redi-Flo pump-end and motor makes it easy to repair and service. The motor lead is also replaceable.

Applications

Remediation/Pollution Recovery/Dewatering

Connection of a sensor such as a pressure transducer enables the pump via the status control box to pump constant level by varying the speed of the pump automatically between 7,000 and 10,700 rpms to maintain desired fluid level. Alternately, a maximum and minimum fluid level can be programmed to control the pump at a set speed.

Maintaining a Constant Water Table

Introduction

By monitoring the water table and by adjusting pump performance, the water table can be maintained at a constant level.

EXAMPLES OF APPLICATION:

For example maintaining a constant water table is useful in the following situations:

- When the groundwater should be kept out of a building site.
- When the salt water should be kept from penetrating a borehole with potable water.

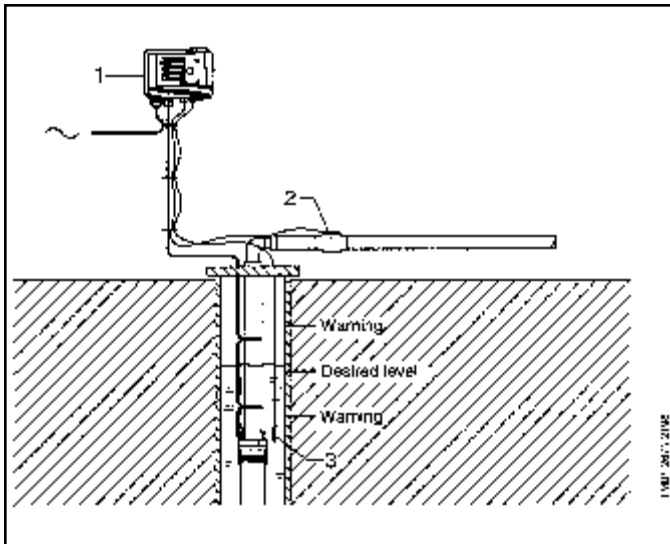

Description

Pos.	Description
1	CU300
2	Analog flow meter
3	Level sensor

Remedial Pumping with Water Quality Monitoring

Introduction

By means of sensor signals it is possible to carry out remedial pumping where the water contains e.g. chemicals, oils, etc.

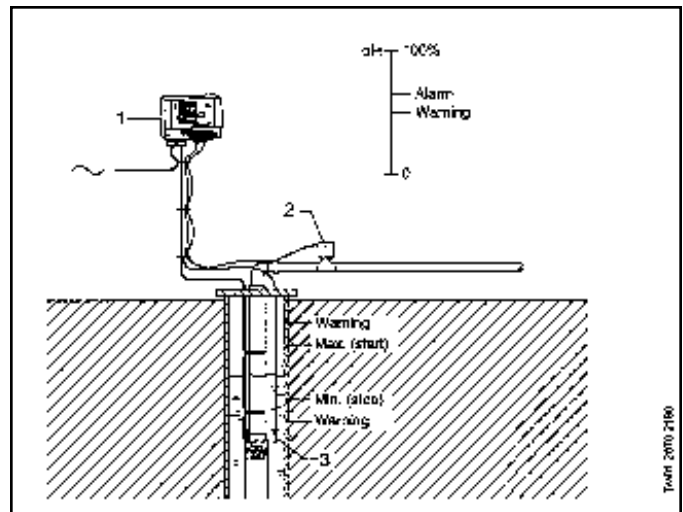

Description

Pos.	Description
1	CU300
2	Analog flow meter Detects the water quality
3	Level sensor

Pumping from One Tank to Another

Where there is a need to move water from one tank to another, the Redi-Flo3 is ideal.

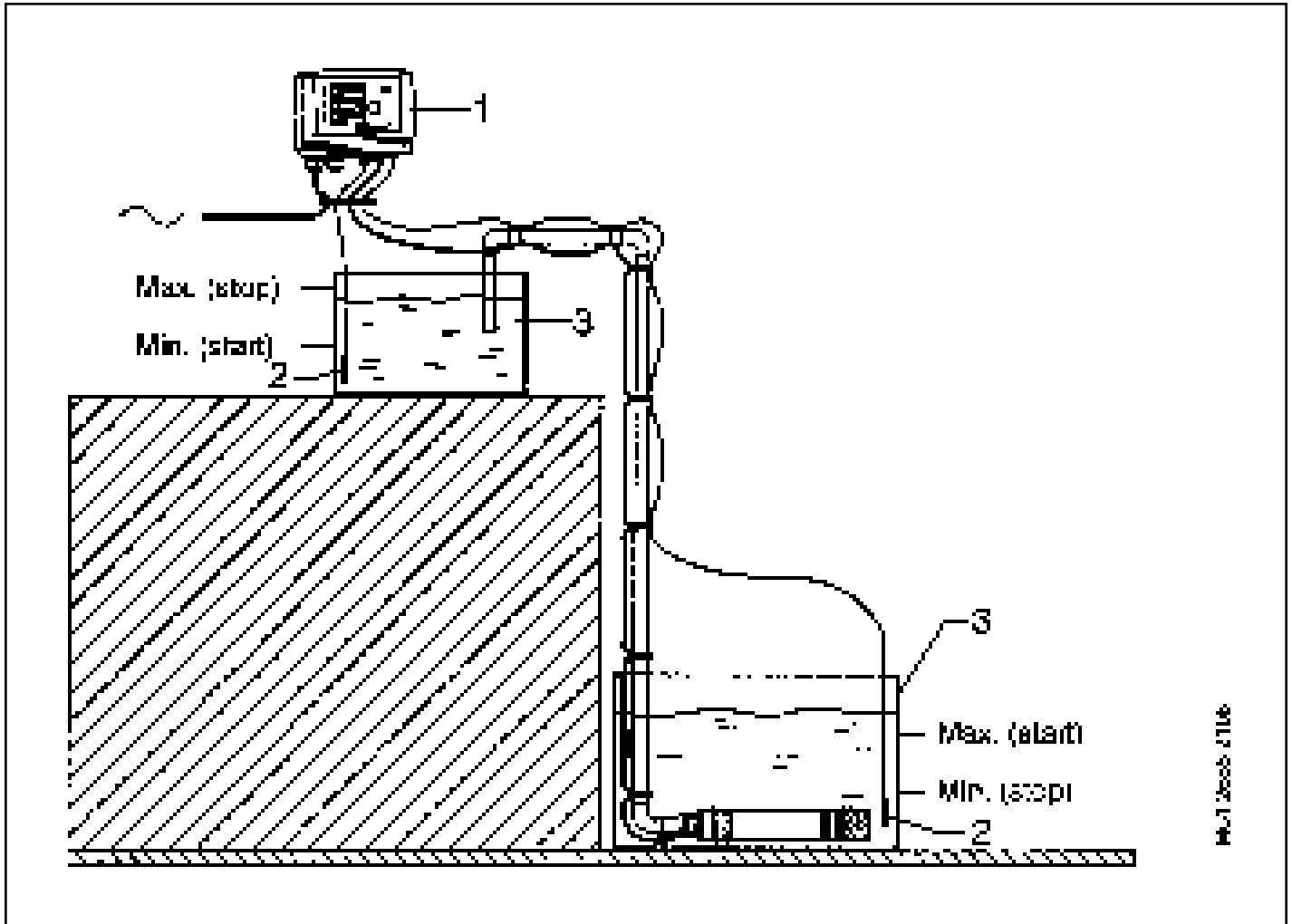

Description

Pos.	Description
1	CU300
2	Level sensor
3	Water tank

NOTE: When the Redi-Flo3 pump is installed horizontally, it is recommended that a flow sleeve be fitted. The motor must be fully submerged in the water.

Sensor 1 (tank at top)

Level	Description
Max. (stop)	When the water has reached this level, the pump stops. Green indicator light in on/off-button flashes.
Min. (start)	When the water has dropped to this level, the pump starts. Green indicator light in on/off-button is constantly lit.

Status Control Box Communication

Redi-Flo3 CU300 Status Box

The CU300 status box is a control and communication unit especially developed for the Redi-Flo3 submersible pumps.

The CU300 status box provides:

- Easy adjustment to a specific well
- Full control of Redi-Flo3 pumps
- Two-way communication with the Redi-Flo3 pumps
- Indicator lights on the front to indicate alarms
- The ability to start and stop the pump with the push of a button.

The CU300 communicates with the pump using the power leads. It is not necessary to run any extra cables between the pump and the CU300 status box.

The following alarms can be indicated by the CU300:

- No Contact
- Overvoltage
- Undervoltage
- Dry-run
- Speed Reduction
- Overtemperature
- Overload
- Sensor Alarm

The CU300 incorporates:

- External signal input for three sensors
- relay output for external alarm reduction
- Control according to the signals received, e.g. flow pressure, water level and conductivity

The CU300 can communicate with the R100 infrared remote control or R100 PC software tool.

R100 Remote Control or PC Software Tool

The R100 allows you to monitor the installation by reading current operating parameters, such as:

- Power Consumption
- Energy Consumption
- Number of Operating Hours

It allows you to change factory settings. A number of settings can be made, such as:

- Speed (Performance)
- Constant Pressure Control Mode
- De-watering Function
- Automatic Restart Time

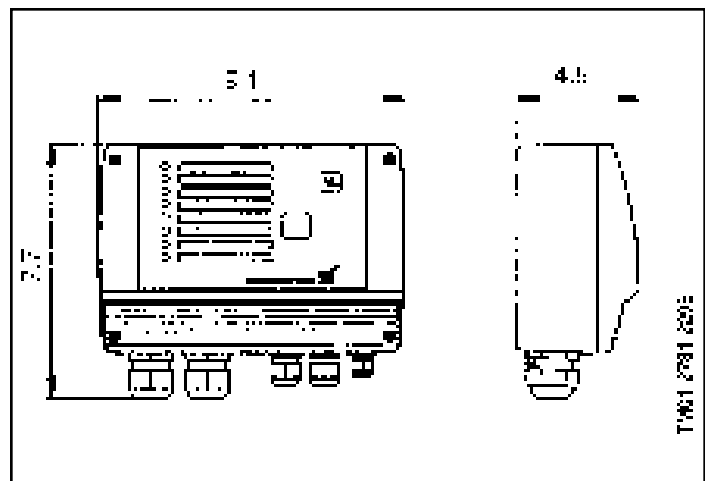
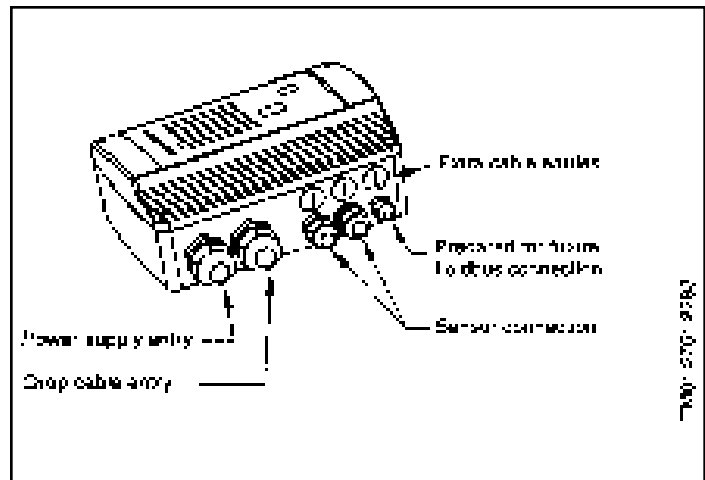
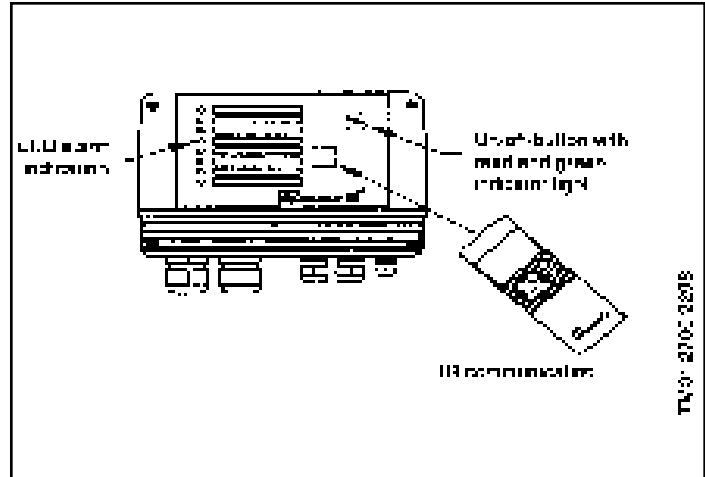

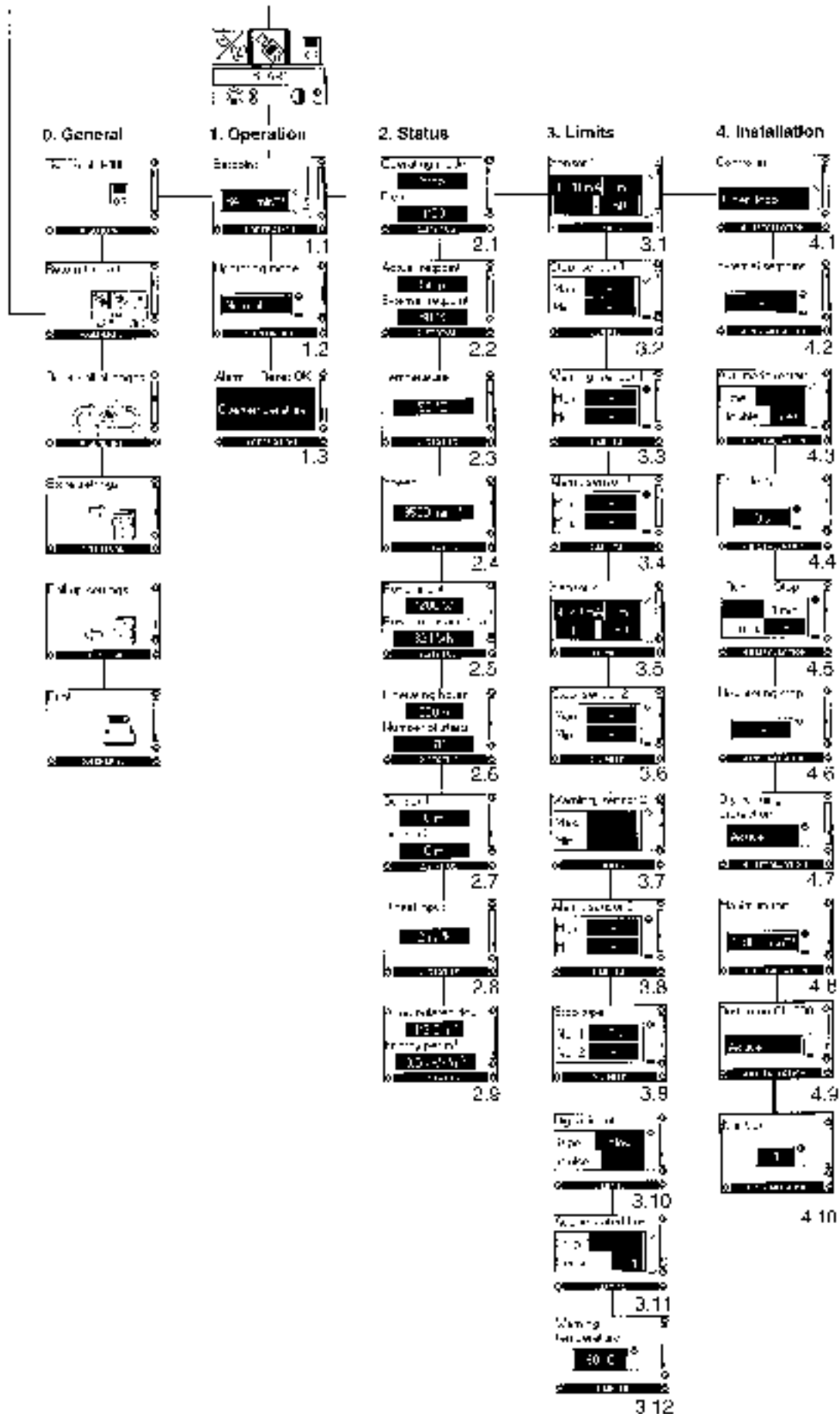

R100 Menu Structure

R100 Menu Structure for the CU300

(ref. CU300 I&O)

0. General

1. Operation

- 1.1 Set-point setting
- 1.2 Selection of operating mode
- 1.3 Alarm indication

2. Status

The indication of:

- 2.1 Actual operating mode
- 2.2 Actual and external set point
- 2.3 Actual motor temperature
- 2.4 Actual motor speed
- 2.5 Actual power input and accumulated motor power consumption.
- 2.6 Accumulated number of operating hours and accumulated number if starts.
- 2.7 Actual values of sensors 1 and 2 respectively
- 2.8 Actual values of the digital input
- 2.9 Accumulated flow, and the power used to pump 1 gal.

R100 allows you to make a number of settings:

3. Limits

The setting of:

- 3.1 Sensor 1
- 3.2 Min. and max. stop limit of sensor 1
- 3.3 Min. and max. warning limit of sensor 1
- 3.4 Min. and max. alarm limit of sensor 1
- 3.5 Sensor 2
- 3.6 Min. and max. stop limit of sensor 2
- 3.7 Min. and max. warning limit of sensor 2
- 3.8 Min. and max. alarm limit of sensor 2
- 3.9 Filling or emptying
- 3.10 Setting of the function of the digital sensor connected to the digital input
- 3.11 The setting of the water quantity stop limit and the setting of the sensor to detect water quantity
- 3.12 The setting of the temperature warning limits of the motor electronics

4. Installation

- 4.1 Selection of controller
- 4.2 Setting of external set-point
- 4.3 Setting of automatic restart time
- 4.4 Allocation of individual start delays
- 4.5 Setting of the stop and run times for the de-watering function
- 4.6 Setting of the minimum value of the pump power input
- 4.7 Activating or deactivating the Dry-Run protection
- 4.8 Setting of the maximum motor speed
- 4.9 Activating or deactivating the on/off-button on the CU 300
- 4.10 Allocation of number where more than one CU 300 is installed

Status report

All settings and measured values can be transferred to a portable printer via wireless infrared communication and be printed in a status report.

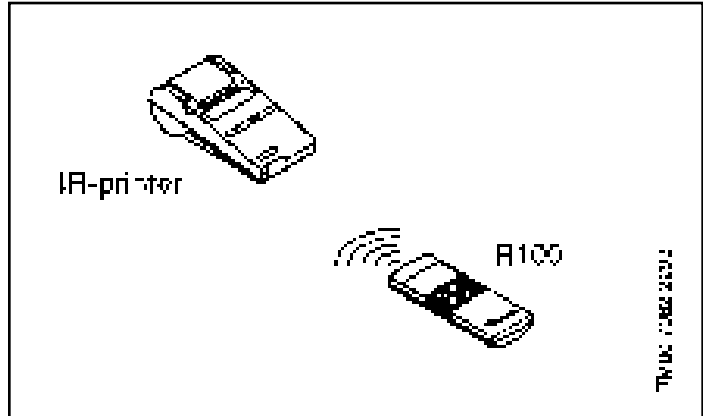

Examples of R100 displays

Menu OPERATION

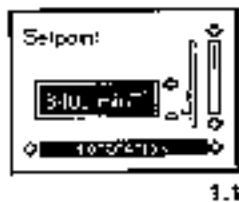

Set-point Setting

From the factory, the pump is set to maximum speed, 10,700 rpm. R100 allows you to reduce the pump speed by changing the set-point. The speed can be set from 7,000–10,700 rpm, at 100 rpm intervals.

The unit of the set-point is automatically changed according to the unit of the sensor connection to sensor input no. 1

EXAMPLE: Sensor input no. 1 is connected to a pressure sensor using the unit feet (ft.) and the range 0 – 200. Therefore, the set-point of display 1.1 can be set to between 0 – 200 ft.

Menu STATUS



The displays appearing in this menu are status displays only. You cannot change settings in this menu.

Example

In display 2.4, the actual speed of the pump is shown.

Accumulated Number of Operating Hours and Number of Starts



The value of operating hours and the number of starts are values accumulated from the time of installation and they cannot be reset.

Both values are stored in the motor electronics, and are kept even if the CU300 is replaced.

The number of operating hours is registered every two minutes of continuous operation.

Menu LIMITS

The Setting of Sensor 1

Depending on the type of sensor, the following settings can be made:

Sensor outputs: (not active), 0-10V, 2-10V, 0-20mA, 4-20mA.

Setting range unit: M3/h, m, %, gpm, ft.

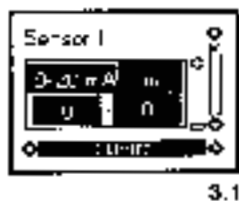

Model #	HP	Size	Disch. Size	Dimensions in Inches					Approx. Ship Wt. (pounds)
				A	B	C	D	E	
5Redi-Flo3-90	1/3A	3"	1" NPT	30.4	19.8	10.6	2.6	2.9	12
5Redi-Flo3-120	1/3A	3"	1" NPT	30.4	19.8	10.6	2.6	2.9	12
5Redi-Flo3-170	1/2A	3"	1" NPT	31.5	19.8	11.6	2.6	2.9	12
5Redi-Flo3-210	1/2B	3"	1" NPT	33.6	19.8	13.7	2.6	2.9	13
5Redi-Flo3-250	1/2B	3"	1" NPT	33.6	19.8	13.7	2.6	2.9	13
5Redi-Flo3-290	3/4B	3"	1" NPT	34.6	19.8	14.8	2.6	2.9	13
5Redi-Flo3-340	1C	3"	1" NPT	38.2	21.3	16.9	2.6	2.9	16
5Redi-Flo3-380	1C	3"	1" NPT	38.2	21.3	16.9	2.6	2.9	16
5Redi-Flo3-420	1C	3"	1" NPT	39.3	21.3	18.0	2.6	2.9	16

Note: Weights include pump ends with motors

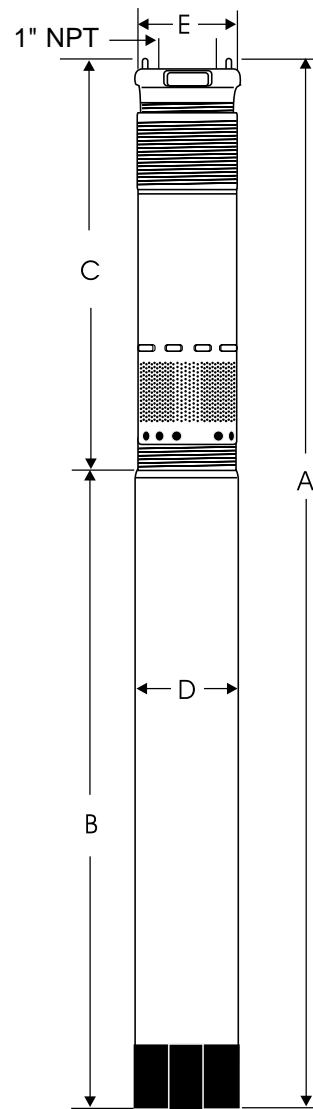
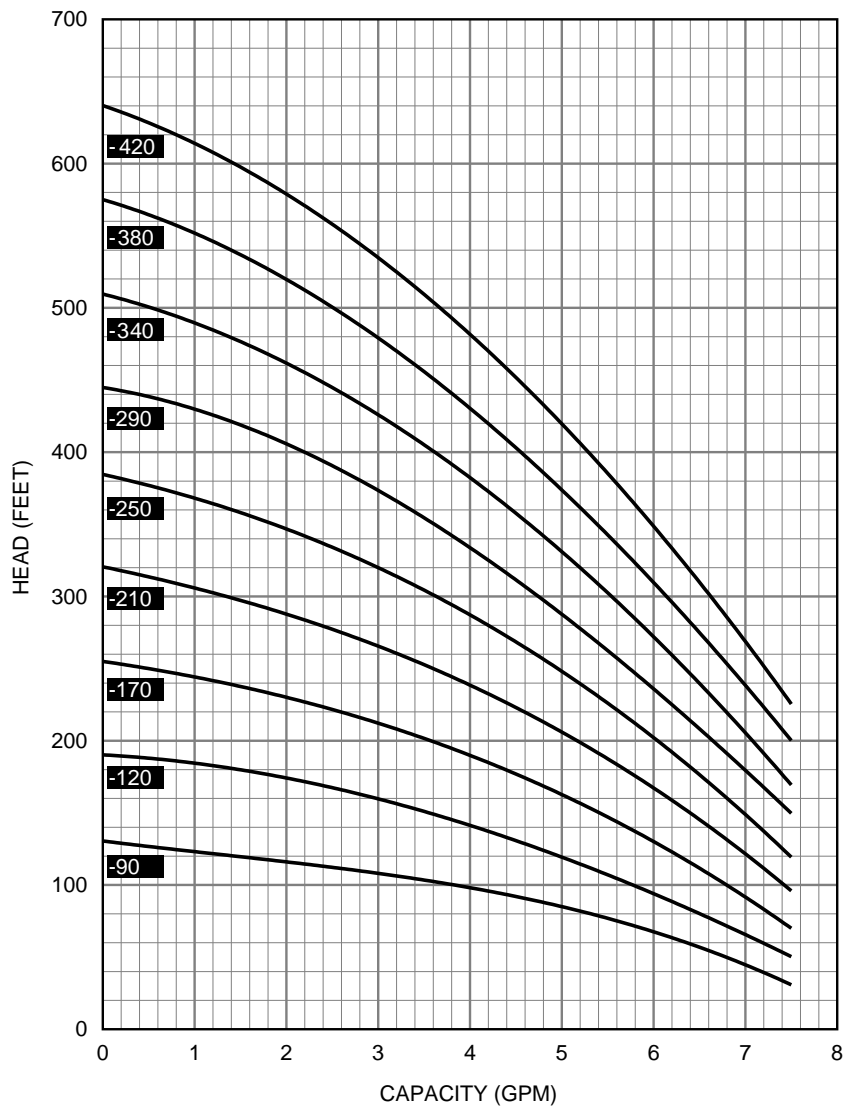

Model #	HP	Size	Disch. Size	Dimensions in Inches					Approx. Ship Wt. (pounds)
				A	B	C	D	E	
10Redi-Flo3-100	1/3A	3"	1 1/4" NPT	30.4	19.8	10.6	2.6	2.9	12
10Redi-Flo3-140	1/2A	3"	1 1/4" NPT	30.4	19.8	10.6	2.6	2.9	12
10Redi-Flo3-180	1/2B	3"	1 1/4" NPT	31.5	19.8	11.6	2.6	2.9	13
10Redi-Flo3-220	3/4B	3"	1 1/4" NPT	33.6	19.8	13.7	2.6	2.9	13
10Redi-Flo3-260	1C	3"	1 1/4" NPT	35.0	21.3	13.7	2.6	2.9	16
10Redi-Flo3-300	1C	3"	1 1/4" NPT	36.1	21.3	14.8	2.6	2.9	16
10Redi-Flo3-340	1 1/2C	3"	1 1/4" NPT	38.2	21.3	16.9	2.6	2.9	16

Note: Weights include pump ends with motors

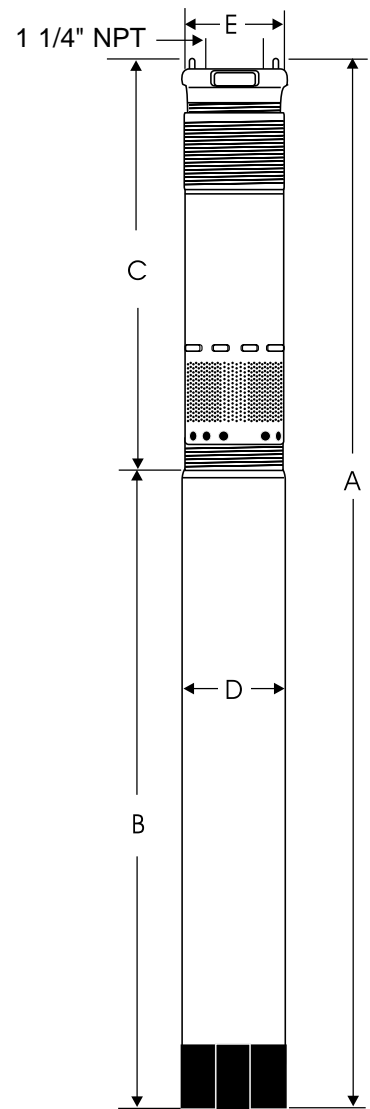
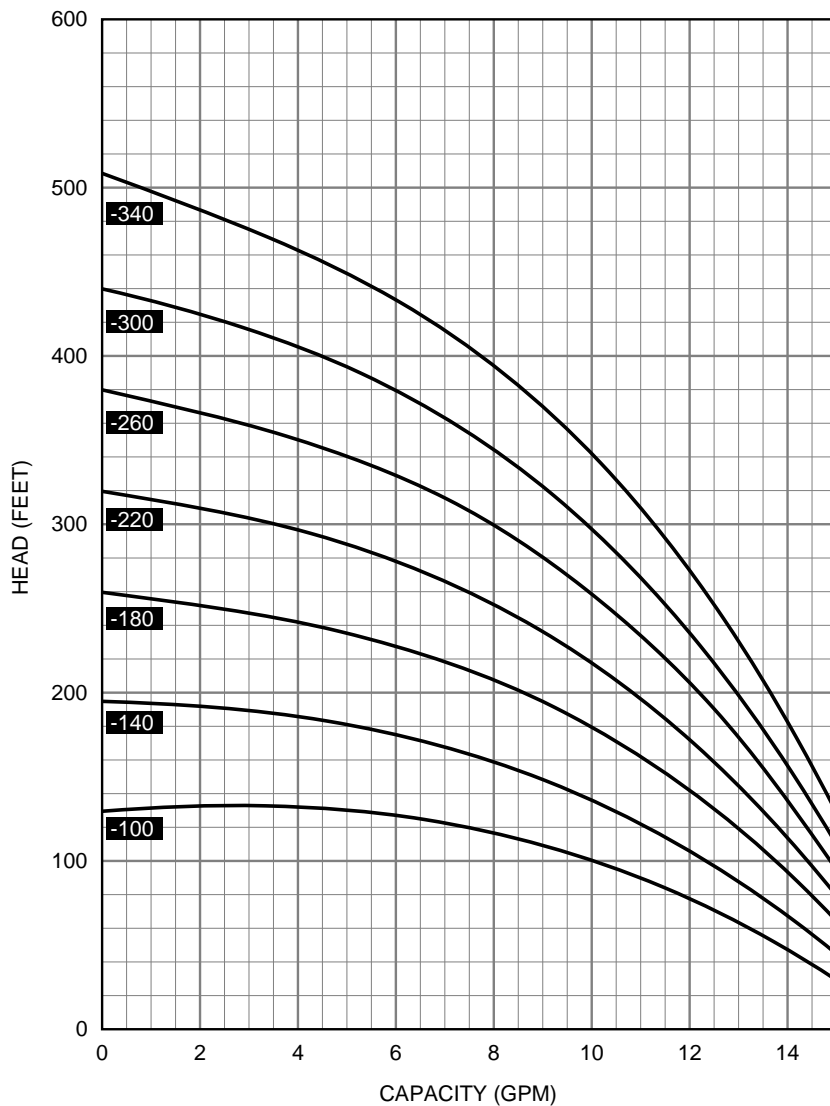

Model #	HP	Size	Disch. Size	Dimensions in Inches					Approx. Ship Wt. (pounds)
				A	B	C	D	E	
15Redi-Flo3-70	1/3A	3"	1 1/4" NPT	30.4	19.8	10.6	2.6	2.9	12
15Redi-Flo3-100	1/2A	3"	1 1/4" NPT	30.4	19.8	10.6	2.6	2.9	12
15Redi-Flo3-130	1/2B	3"	1 1/4" NPT	31.5	19.8	11.6	2.6	2.9	13
15Redi-Flo3-170	3/4B	3"	1 1/4" NPT	33.6	19.8	13.7	2.6	2.9	13
15Redi-Flo3-200	1C	3"	1 1/4" NPT	35.0	21.3	13.7	2.6	2.9	16
15Redi-Flo3-230	1C	3"	1 1/4" NPT	36.1	21.3	14.8	2.6	2.9	16
15Redi-Flo3-270	1 1/2C	3"	1 1/4" NPT	38.2	21.3	16.9	2.6	2.9	16

Note: Weights include pump ends with motors

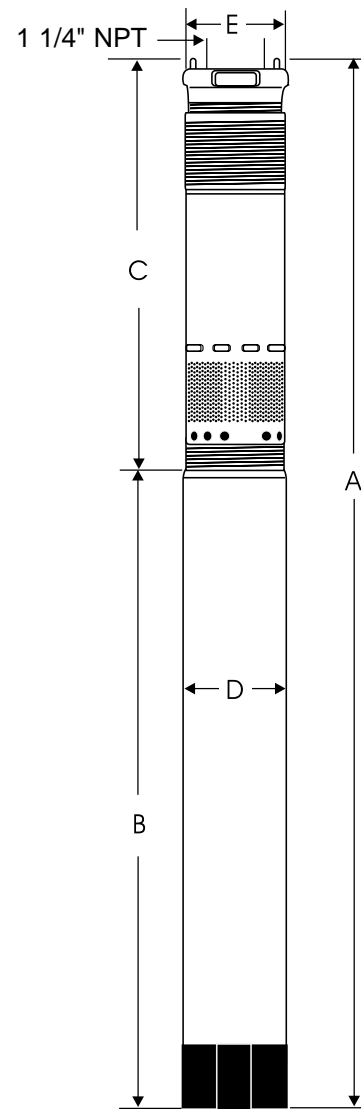
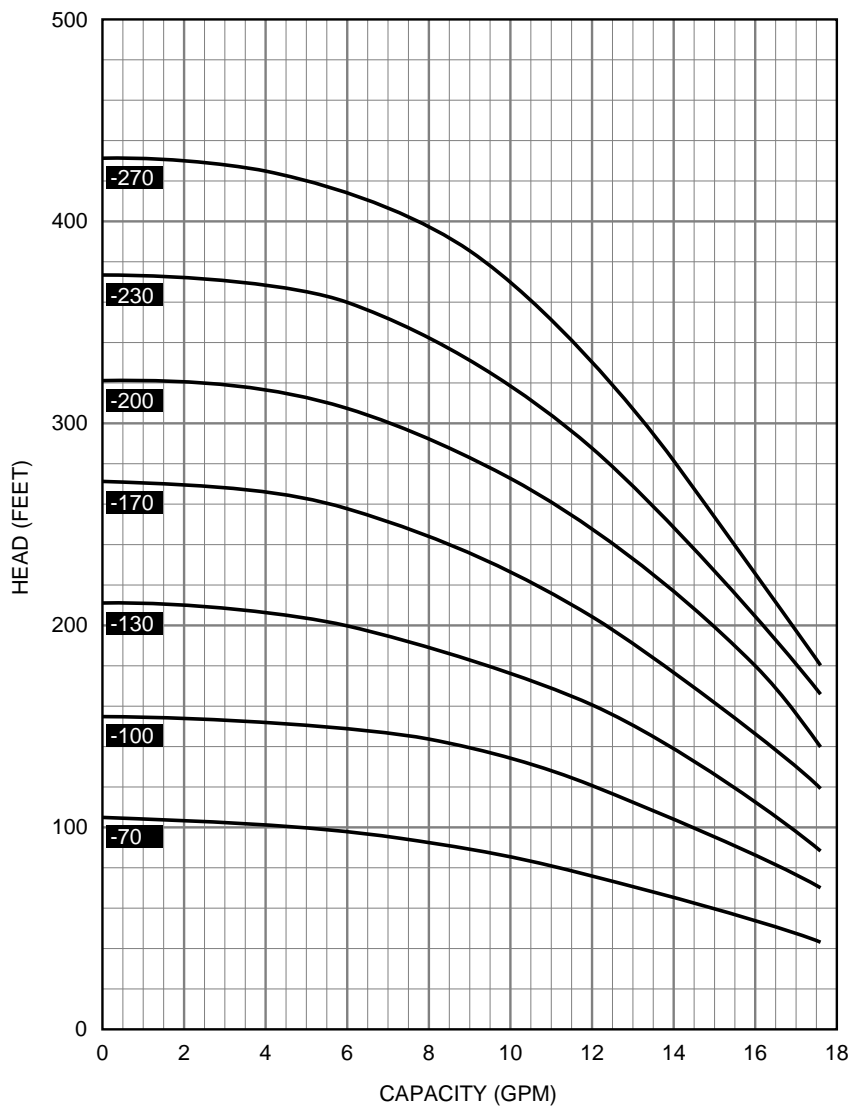

Model #	HP	Size	Disch. Size	Dimensions in Inches					Approx. Ship Wt. (pounds)
				A	B	C	D	E	
22Redi-Flo3-40	1/3A	3"	1 1/2" NPT	30.4	19.8	10.6	2.6	2.9	12
22Redi-Flo3-80	1/2A	3"	1 1/2" NPT	30.4	19.8	10.6	2.6	2.9	12
22Redi-Flo3-110	1/2B	3"	1 1/2" NPT	31.5	19.8	11.6	2.6	2.9	13
22Redi-Flo3-140	3/4B	3"	1 1/2" NPT	33.6	19.8	13.7	2.6	2.9	13
22Redi-Flo3-180	1C	3"	1 1/2" NPT	38.2	21.3	16.9	2.6	2.9	16
22Redi-Flo3-210	1 1/2C	3"	1 1/2" NPT	38.2	21.3	16.9	2.6	2.9	16

Note: Weights include pump ends with motors

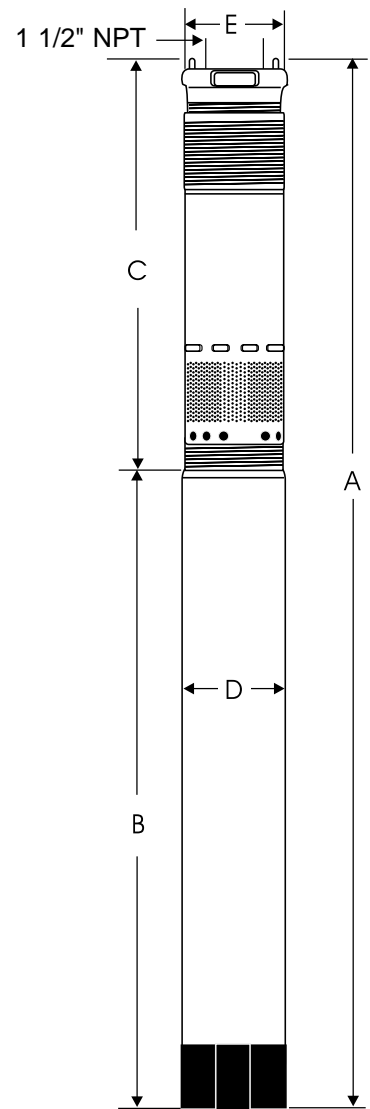
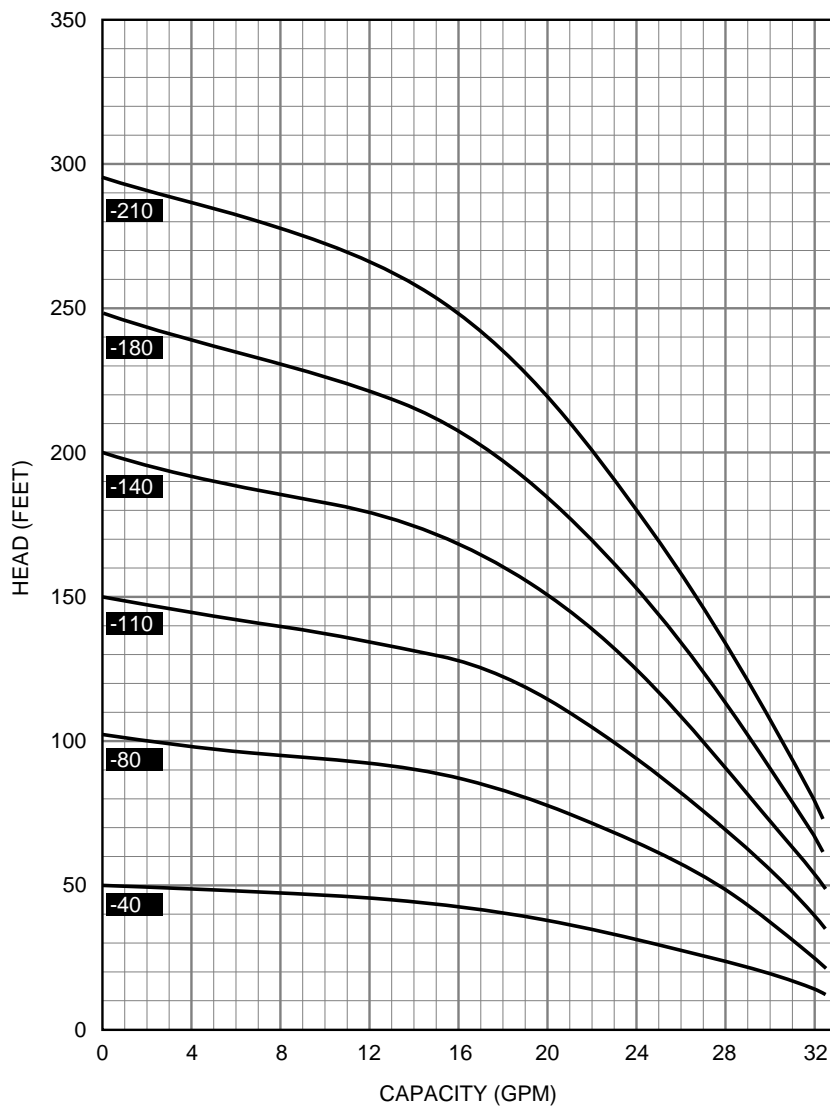

Model #	HP	Size	Disch. Size	Dimensions in Inches					Approx. Ship Wt. (pounds)
				A	B	C	D	E	
30Redi-Flo3-40	1/2A	3"	1 1/2" NPT	30.4	19.8	10.6	2.6	2.9	12
30Redi-Flo3-80	1/2B	3"	1 1/2" NPT	30.4	19.8	10.6	2.6	2.9	13
30Redi-Flo3-120	1C	3"	1 1/2" NPT	35.0	21.3	13.7	2.6	2.9	13
30Redi-Flo3-160	1 1/2C	3"	1 1/2" NPT	35.0	21.3	13.7	2.6	2.9	16

Note: Weights include pump ends with motors

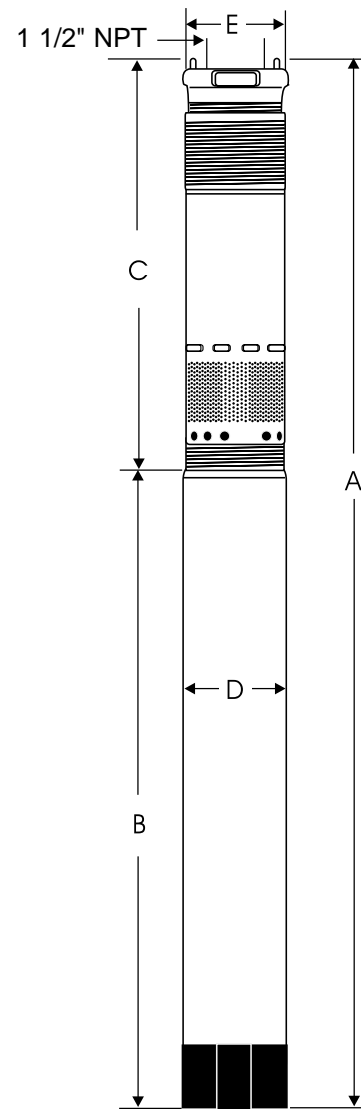
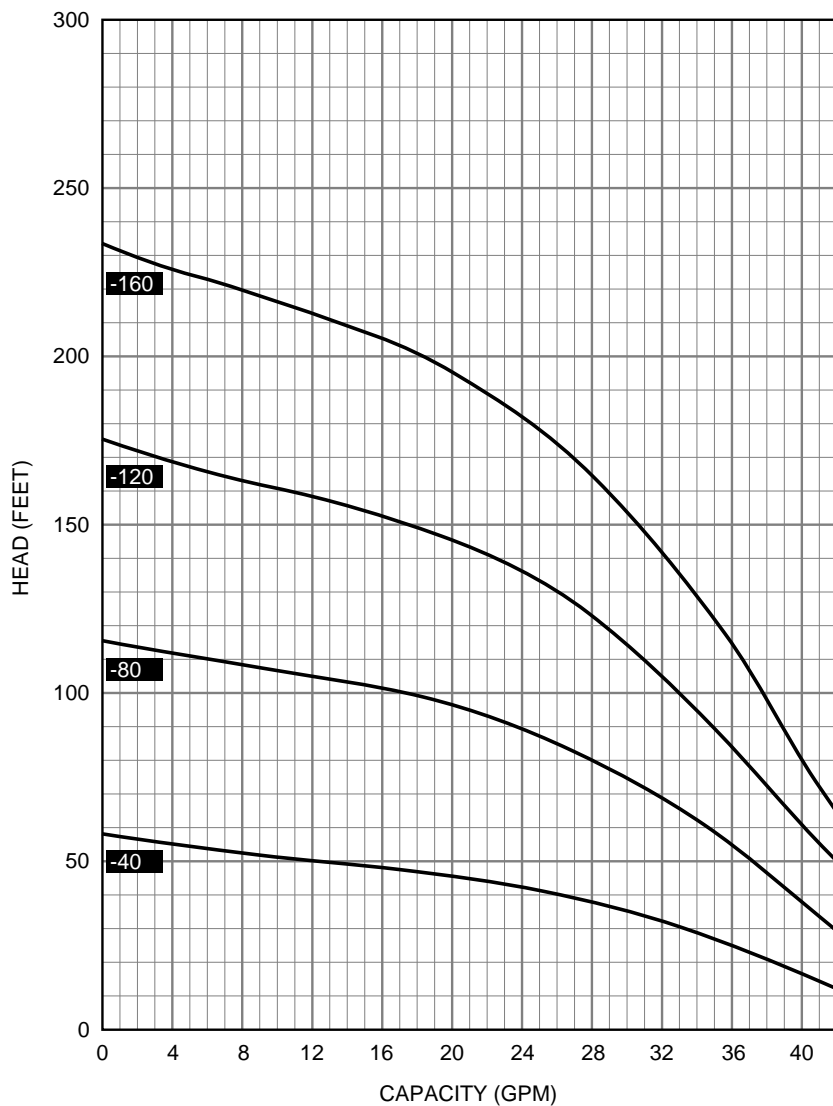

Redi-Flo3 Technical Specifications

MATERIAL SPECIFICATION – REDI-FLO3 PUMP END

Pos.	Component	Material	DIN W. Nr.	AISI
1	Valve Casing	PVDF		
1a	Discharge Chamber	Stainless Steel	1.4401	316
1d	O-Ring	FPM Rubber		
2	Valve Cone	PVDF		
3	Valve Seat	FPM Rubber		
4	Top Chamber	PVDF		
4a	Empty Chamber	PVDF		
6	Top Bearing	FPM Rubber		
7	Neck Ring	PVDF		
7a	Lock Ring	Stainless Steel	1.4401	316
9a	Guide Vanes	PVDF		
10	Bottom Chamber	PVDF		
13	Impeller w/ tungsten carbide bearing	PVDF		
14	Suction Interconnector	PVDF		
14a	Ring	Stainless Steel	1.4401	316
16	Shaft w/ coupling	Stainless Steel	1.4401	316
		Sintered Steel		
18	Cable Guard	Stainless Steel	1.4401	316
18a	Cable Guard Screws	Stainless Steel	1.4401	316
30	Pressure Equalization Cone	PVDF		
39	Valve Spring	Stainless Steel	1.4406	316LN
55	Pump Sleeve	Stainless Steel	1.4401	316
70	Valve Guide	PVDF		
85a	Spacer	Stainless Steel	1.4401	316

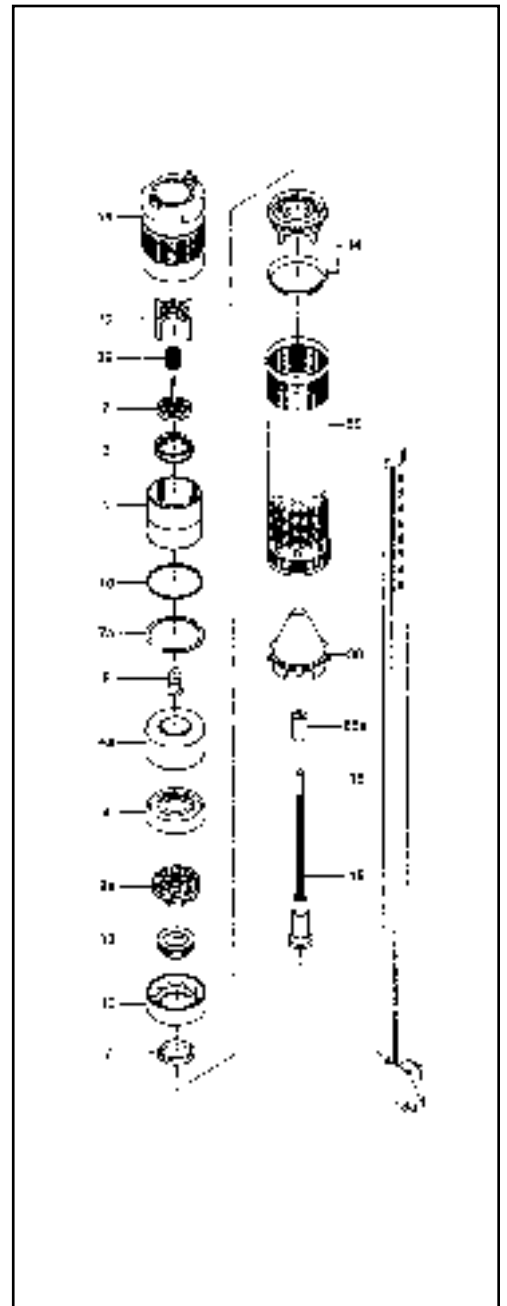

Redi-Flo3 Technical Specifications

MATERIAL SPECIFICATION – REDI-FLO3 PUMP MOTOR

Pos.	Component	Material	DIN W. Nr.	AISI
1	Stator	Stainless Steel	1.4401	316
2	Rotor	Stainless Steel	1.4401	316
2a	Stop Ring	PP		
2b	Filter	Polyester		
3	Thrust Bearing	Carbon		
5	Radial Bearing	Ceramic/ tungsten carbide		
20	Motor Cable w/ plug	Tefzel		
		PVDF		
22a	Filling Plug	FPM Rubber		
24	O-Ring	FPM Rubber		
24a	O-Ring	FPM Rubber		
25	Top Cover	PPS		
27	Filter	Polyester		
32	Shaft Seal	FPM Rubber		
	Motor Liquid	SML-2		

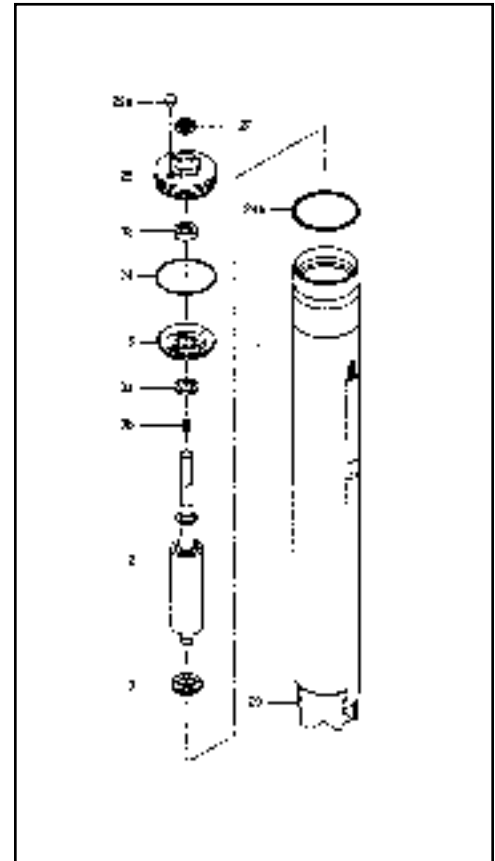

Redi-Flo3 Technical Data

ELECTRIC	
Supply Voltage:	1x200-240V +6%/-10%, 50/60 Hz, PE 1x100-115V
Operation via Generator:	As a minimum, the generator output must be equal to the motor P1[KW] +10%
Starting Current:	The motor starting current is equal to the highest value stated on the motor nameplate
Starting:	Soft-start
Run-up Time:	Maximum: 2 seconds
Motor Protection:	The motor is protected against: Dry running, overvoltage, undervoltage, overload, overtemperature
Power Factor:	PF=1
Service Factor:	0.33-0.50A[Hp]-1.75 at 115V/230V 0.50-0.75B[Hp]-1.4 at 230V 1.0-1.5C[Hp]-1.15 at 230V
Motor Cable:	3 Wire, Tefzel Cable Kit
Motor Liquid:	Type SML 2
pH Values:	4-9
Liquid Temperature:	The temperature of the pumped liquid should not exceed 104°F.
Note: If liquids with a viscosity higher than that of water are to be pumped, please contact GRUNDFOS	
Minimum Ambient Temperature:	-4°F
Maximum Ambient Temperature:	+140°F
Frost Protection:	If the pump is to be stored after use, it must be stored in a frost-free location or it must be ensured that the motor liquid is frost-proof. Otherwise motor must be stored without being filled with motor liquid.
OPERATING CONDITIONS	
Minimum Ambient Fluid Temperature:	-4°F
Maximum Ambient Fluid Temperature:	+104°F
APPROXIMATE DIMENSIONS AND WEIGHT	
Motor Dimensions (MSE - NE 3):	
0.33-0.50A[Hp]	20.9" length x 2.68" diameter
0.50-0.75B[Hp]	20.9" length x 2.68" diameter
1.0-1.5C[Hp]	22.3" length x 2.68" diameter
Pump Diameter, incl. cable guard:	2.91"
Motor Weights (MSE - NE 3):	
0.33-0.50A[Hp]	6.0 lbs
0.50-0.75B[Hp]	7.1 lbs
1.0-1.5C[Hp]	8.2 lb
Pump End Dimensions:	
Pump Diameter:	2.68"
Pump Diameter, incl. cable guard:	2.91"
Pump End Dimensions (min. and max.):	
5 Redi-Flo3	10.6" to 18.0"
10 Redi-Flo3	10.6" to 16.9"
15 Redi-Flo3	10.6" to 16.9"
22 Redi-Flo3	10.6" to 16.9"
30 Redi-Flo3	10.6" to 13.7"
Pump End Weights (min. and max.):	
All	2.2 lbs to 3.5 lbs
Well Diameter (minimum):	3"
Installation Depth (maximum):	500 feet, below static water level

Redi-Flo3 Accessories

CU300 Status Box

Description	Product no.
CU300 Status Box	96422776

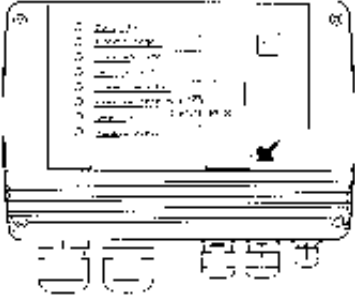

CU 300 PC Tool Software

Description	Product no.
CU 300 PC Tool Software	96432875

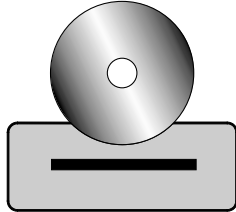

R100 Remote Control

Description	Product no.
The R100 is used for wireless infrared communication with the CU300	625333

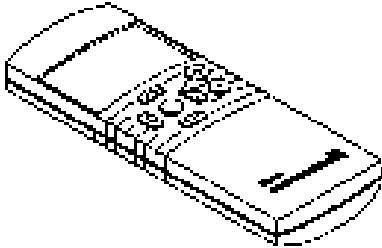

Printer

Description	Product no.
Printer for R100, infrared communication Type: Hewlett Packard, HP 82240B	620480
Paper Roll	620481

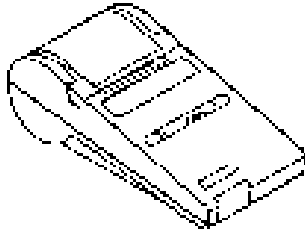

Potentiometer

Description	Version	Product no.
External potentiometer with cabinet for wall mounting. Screened cables, 4-wire cable, max. length of cable: 100m	Grundfos potentiometer, SPP1 Enclosure class: IP 55	655468

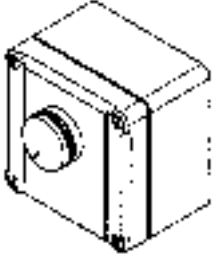
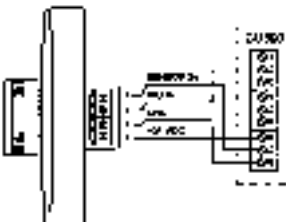
Redi-Flo3 - Flow Sleeve

Description	Product no.
Flow Sleeve Complete	96037505

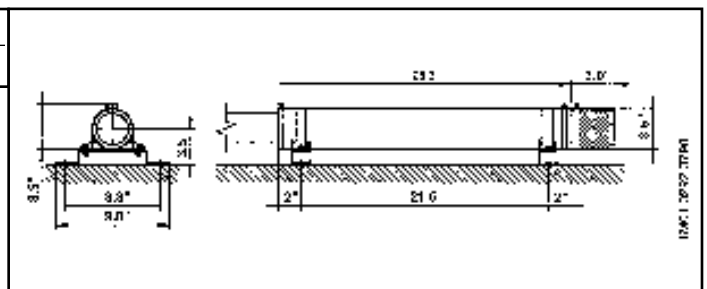

GRUNDFOS®



Leaders in Pump Technology

Grundfos Pumps Corporation • 3131 N. Business Park Avenue • Fresno, California 93727

Customer Service Centers: Allentown, PA • Fresno, CA

Phone: (800) 333-1366 • **Fax:** (800) 333-1363

Canada: Oakville, Ontario • **Mexico:** Apodaca, N.L.

Visit our website at www.us.grundfos.com



L-RF-TL-014	Rev. 7/00
PRINTED IN USA	