

Model 2P5XHR

2" Engine Driven Self-Priming Portable High Pressure Pumps

- **Cast Aluminum Construction**
- **EPDM/EPR Mechanical Seals**
- **2" Cast Iron Suction & Discharge Male NPT Port Sizes**
- **Maximum Flow up to 130 GPM**
- **Maximum Head up to 108 PSI**
- **Maximum Lift to 26 Ft.**
- **One Tool Serviceability**
- **Utilized for Fire Protection or Irrigation**
- **Discharge Port Rotates in 90° Increments**
- **Optional High Pressure Hose Kit and Wheel Kit Available**



Optional High Pressure Hose Kit 55-338

IPT 2" Self-Priming Engine Driven Portable High Pressure pumps are cast aluminum construction with cast iron volute and male NPT ports. Pump applications include fire protection, agricultural spraying and irrigation. These pumps are available with a wide choice of standard and heavy duty gasoline or diesel fueled engines. These pumps feature closed cast aluminum impeller. All models come equipped with EPDM/EPR elastomers and seals. Most models include a heavy duty steel roll frame.

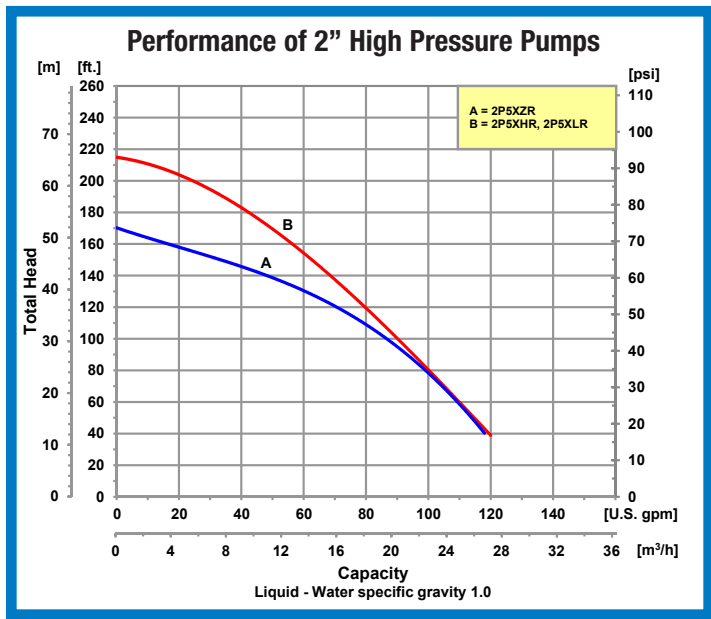



Self-Priming Portable High Pressure Pumps

Pump Dimensional & Specification Data

Model	Curve	Driver	Seal Types & Elastomers/Faces	Tank Size (Gal/Ltr)	Run Time (Hr.)	Mounting	Ship Wt. (Lbs.)
2P5XKR	B	Kohler ▲	EPDM/EPR/CAR/CER	0.71/2.7	2.2	Roll Cage	95
2P5XHR	B	Honda GX160 ▲	EPDM/EPR/CAR/CER	0.82/3.1	2.8	Roll Cage	90

Construction: Cast Aluminum with Cast Iron Components
 ++ 12V DC Electric Start (Battery Not Included)
 ▲ Oil Alert Included

5/8 Threaded Kit (Single)

Model	Seal Type & Elastomer/Faces	Mounting	Ship Wt. (Lbs.)
2P5X	EPDM/EPR/CAR/CER	Handle	35

2" High Pressure Hose Kit

Model	Ship Wt. (Lbs.)
55-338	40

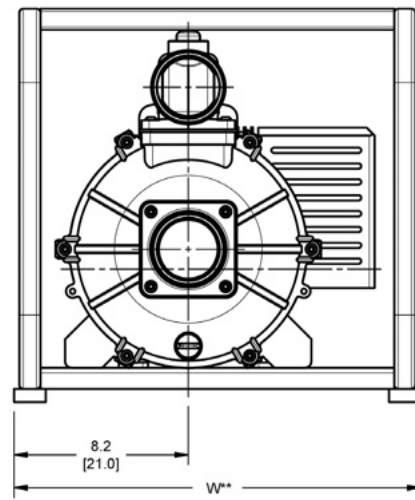
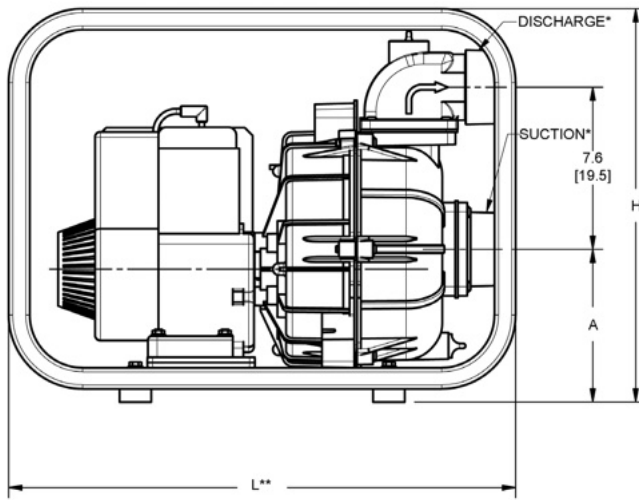

Model	HP Class ♦	SUC*	DIS*	L**	W	H	A
2P5X	5 HP	2	2	24.0 [60.9]	19.5 [50.5]	19.9 [50.5]	7.4 [18.7]

♦ HP Class represents market category and is not intended to define actual horsepower.
 (*) Standard NPT (Male) pipe thread.
 (**) This dimension may vary due to engine manufacturer's specifications.
 NOTE: Dimensions are in inches (centimeters) and have a tolerance of ± 1/8".

Standard Features

- Aluminum Closed Impeller and Cast Iron Volute— Die Cast Aluminum Pump
- Large Pump Casing Increases Capacity
- Built-in Check Valve for Fast Priming
- Removable/Replaceable Cast Iron Suction & Discharge Flanges
- Discharge Port Rotates in 90° Increments
- EPDM/EPR Seal with Carbon and Ceramic Faces with Optional Viton® Seals and Elastomers
- One Tool Serviceability, Tool Included with Engine Driven Models (Not with Kits)
- Choice of LCT Storm Force, Honda Gasoline or Hatz Diesel Engines
- Includes Strainer and Rubber Foot Mounting
- Maximum Temperature 180° F
- Pedestal Versions Available
- Optional High Pressure Hose Kit and Wheel Kit Available
- QSP – Quick Ship Pumps