

Engine Driven Solids Handling Pumps

3" Solids Handling Pumps

Model	Curve	Port	Driver	Seals	Run Time (Hours)	Tank Size (Gal/Ltr.)	Ship Wt. (Lbs.)
3391-V5	A	3" NPT	Honda GX270 ++ ▲	Viton®	2.5	1.40/5.2	170

Construction: Cast Iron

Maximum Solids Handling Capacity: 3/4" Diameter

(♦) HP Class represents market category and is not intended to define actual horsepower

(*) Standard NPT pipe thread

(**) This dimension may vary due to engine manufacturer's specifications.

NOTE: Dimensions are in inches (centimeters) and have a tolerance of ± 1/8".

++ 12V DC Electric Start (Battery Not Included)

▲ Oil Alert Included

Model	HP Class ♦	SUC*	DIS*	L**	W**	H
339 Series	8 HP	3" NPT	3" NPT	31.0 [78.7]	22.5 [57.1]	23.6 [59.9]

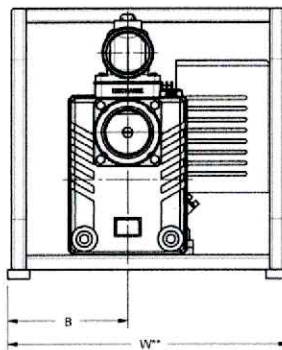
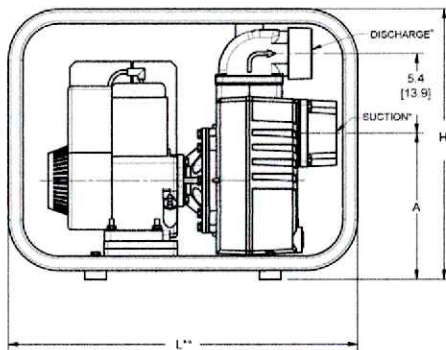

Optional Wheel Kit
For Roll Frame Pumps

Model	Features	Ship Wt. (Lbs.)
C402-90	Includes 10" semi-pneumatic tires on steel wheels with steel clamps and handles for universal mounting to frame.	25

Standard Features

- Viton® Mechanical Seals
- Self-primers to 20 Ft.
- Semi-open, Clog Resistant Cast Iron Impeller
- Stainless Steel Shaft Sleeve
- Maximum Temperature:
Buna-N 180° F
Viton® 200° F
- Maximum Working Pressure 75 PSI
- Wear Resistant Cast Iron Construction and Solids Handling Impeller
- Built-in Check Valve
- Heavy Duty Steel Roll Frame Included
- Pipe Nipple/Discharge Elbow/Strainer
 - 316 Series Includes: (1) Pipe Nipples, (1) Discharge Elbow & (1) Strainer
 - 339 Series Includes: (1) Pipe Nipple, (1) MNPT Discharge Elbow & (1) Strainer
- QSP – Quick Ship Pumps for Many Models