

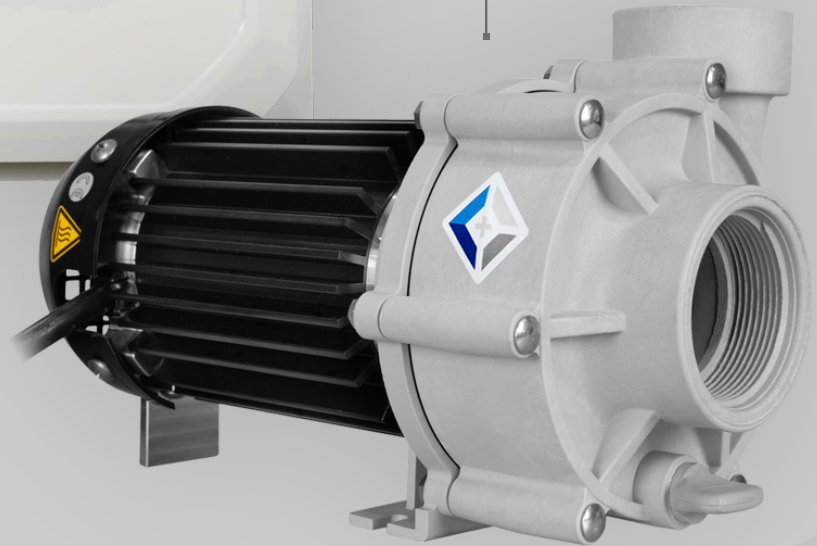

DC MOTOR
VARIABLE SPEED
PUMP

SPEED
CONTROLLER
& POWER SUPPLY



COLOSSAL PERFORMANCE & CONTROL

The MDM Sequence® product family introduces the Colossus 750 DC+, a compact, speed controllable, 120 GPM pump offering direct as well as remote control through third party Internet of Things (IoT) modules. The recent Colossus impeller technology boasts a 16% increase in flow over the synchronous speed legacy impeller designs. Now with speed control capability and energy efficiency that comes with DC motor technology, the performance benefits address the ever-growing demand of high flow, low energy consumption, and small form factor.

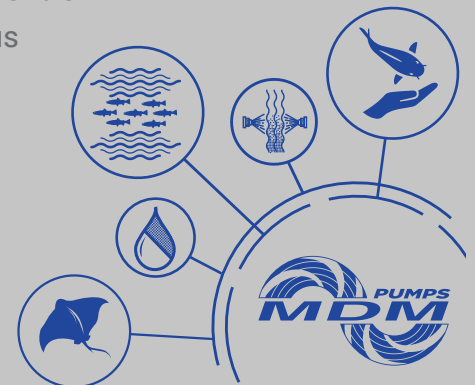

SPEED CONTROLLER & POWER SUPPLY

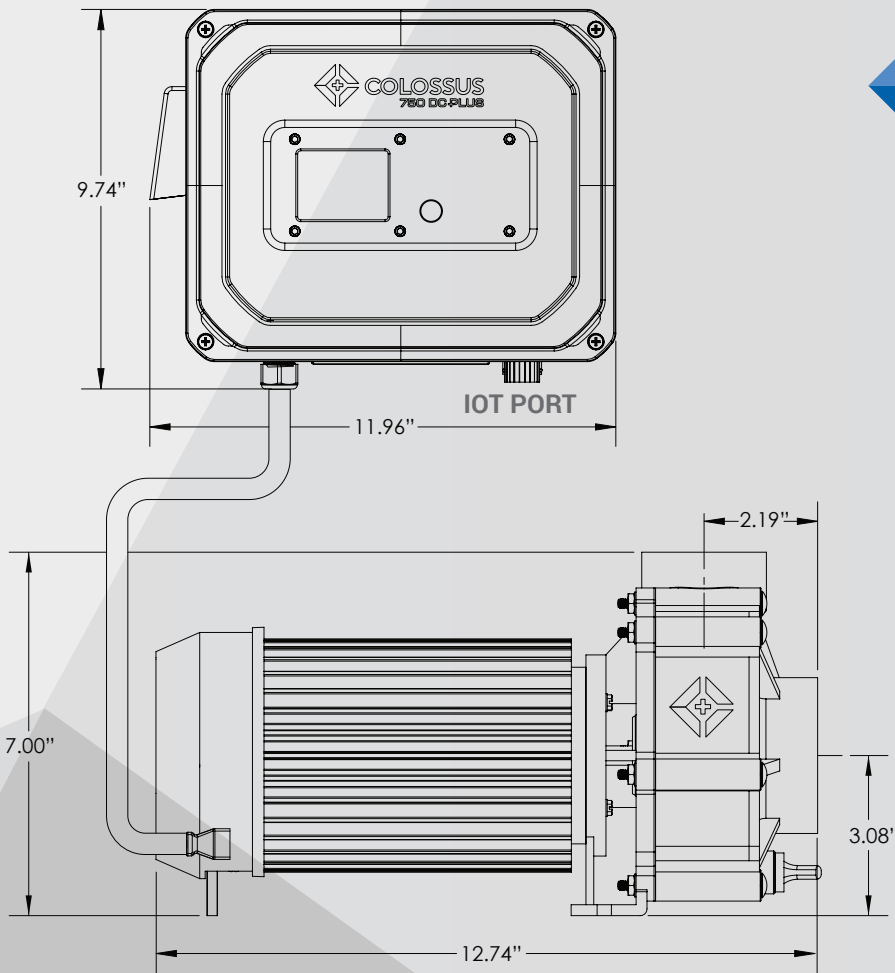

COLOSSUS 750 DC PLUS

FEATURES

- Overload & Run-Dry Protection
 - IoT Controller Ready
 - Compact Footprint
 - Five Year Warranty
-
- 120 GPM Max*
 - 39 Feet Max*
 - Wide Range Speed Control
 - Quiet Operation

