

General Purpose Laundry Tray Pump

- **Cast Aluminum Construction**
- **Buna-N Mechanical Seal and O-ring**
- **1-1/4" NPT Suction and Discharge Port**
- **Solids Handling and Dirty Water Design**
- **Maximum Temperature 180° F**
- **Maximum Flow 24 GPM**
- **Maximum Head 11 Ft. (5.2 PSI)**
- **Self-Cleaning, Semi-Open Impeller**
- **1/4 HP, 115 VAC Single Phase Open Drip Proof (ODP) 1725 RPM 48Z Frame Motor**
- **Continuous Duty Motor**



Model 3201-96

The AMT Laundry Tray pump is a single stage, multi-vane open impeller unit. It is designed as a "laundry tray" pump, but can be used for most gravity fed general service pumping applications. The 1/8" diameter solids handling open impeller design makes it particularly adaptable to dirty, as well as clean liquids and is inherently resistant to clogging. Pumps are designed to handle liquids with solids content or dissolved solids and debris. The pump is constructed of cast aluminum and features 1-1/4" NPT suction and discharge ports. Pump is powered by a 1725 RPM, 115 VAC, 1/4 HP motor. **Pumps are not self-priming and require flooded suction.**

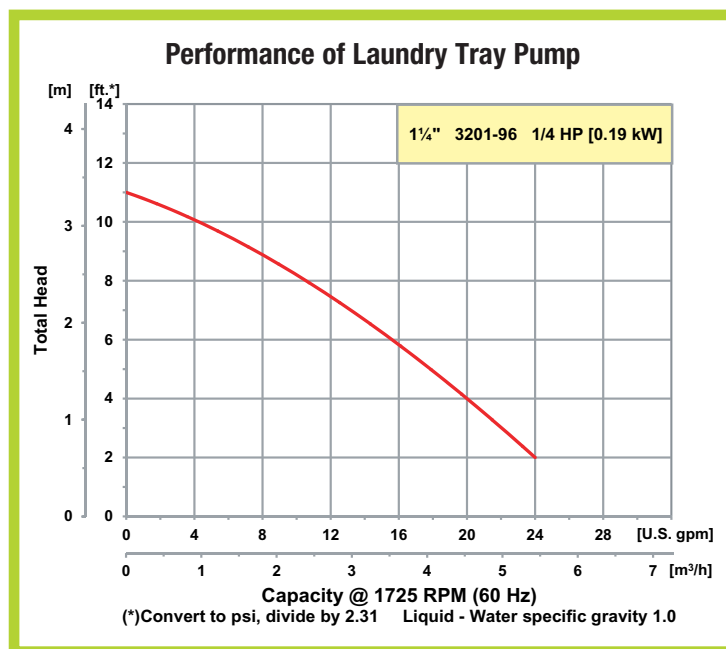

General Purpose Laundry Tray Pump

Pump Dimensional & Specification Data

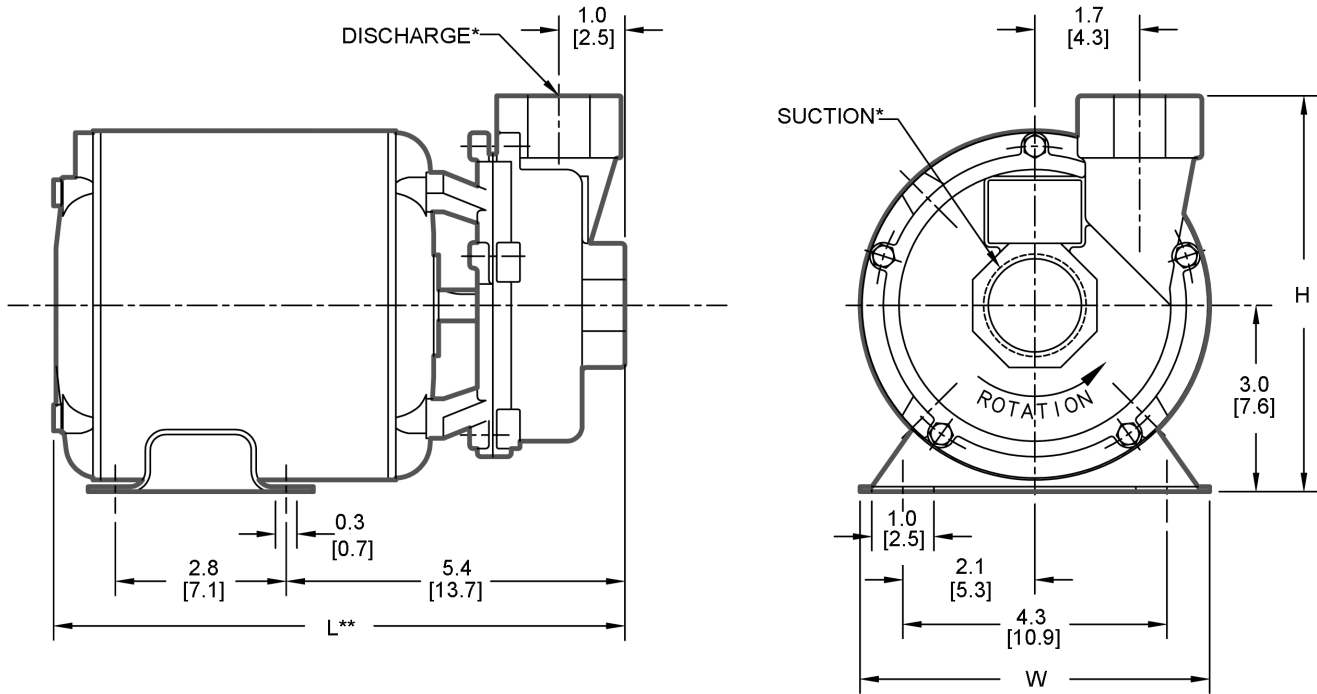

Model	HP	PH	ENC	Voltage @ 60 Hz	Full Load Amps	SUC*	DIS*	L**	W	H	Ship Wt. (Lbs.)
3201-96	1/4	1	ODP	115	4.5	1/4	1/4	9.2 [23.3]	5.6 [14.2]	6.4 [16.2]	13

(*) Standard NPT (Female) pipe thread.

(**) This dimension may vary due to motor manufacturer's specifications.

NOTE: Dimensions are in inches [centimeters] and have a tolerance of $\pm 1/4"$.

NOTE: Electric supply for ALL motors must be within $\pm 10\%$ of nameplate voltage rating (e.g. 230V $\pm 10\%$ = 207 to 253).

Maximum Solids Handling Capacity: 1/8" Diameter

Standard Features

- Cast Aluminum Construction
- Buna-N Mechanical Seal and O-ring
- 1-1/4" NPT Suction and Discharge Ports
- Maximum Working Pressure 50 PSI
- Maximum Temperature 180° F
- Maximum Flow 24 GPM
- Maximum Head 11 Ft.
- Self-cleaning, Semi-open Impeller
- 1725 RPM 1/4 HP 115 VAC Single Phase, Open Drip Proof (ODP) 48Z Frame Motor
- QSP – Quick Ship Pumps