

# Stainless Steel Straight Centrifugal Pumps

High Volume Pump

- **Stainless Steel Construction with Viton® Mechanical Seal and O-Ring**
- **Investment Cast Stainless Steel Impeller**
- **Solid Handling and Dirty Water Design**
- **Maximum Temperature 200° F**
- **Maximum Flow 156 GPM**
- **Maximum Head 130 Ft.**
- **Chemical Resistant Design**
- **Discharge Port Rotates in 90° Increments**
- **547 Series: 3/4" x 1/2" Ports and 1-1/4" x 3/4" Ports**
- **548 Series: 1-1/2" x 1-1/4"**
- **549 Series: 2" x 1-1/2" Ports**

AMT Stainless Steel Solids Handling End Suction Centrifugal pumps are designed for continuous duty high flow and high pressure applications including: chemical processing, liquid transfer, pressure boosting, circulating, dirty water. Constructed of rugged deep drawn stainless steel for durability and corrosion resistance. Investment cast stainless steel closed impeller for enhanced performance, and handles a maximum of 1/8" diameter solids.

All models include Viton® Type 21 mechanical seals and O-rings which offer a broad range of chemical compatibility. Cast iron motor adapter provides a positive and rigid mounting to motor. Pumps include Totally Enclosed Fan Cooled (TEFC) motors or Open Drip Proof (ODP) motors by special quote. **Pumps are not self-priming and require flooded suction.**

Performance of Stainless Steel Straight Centrifugal Pumps

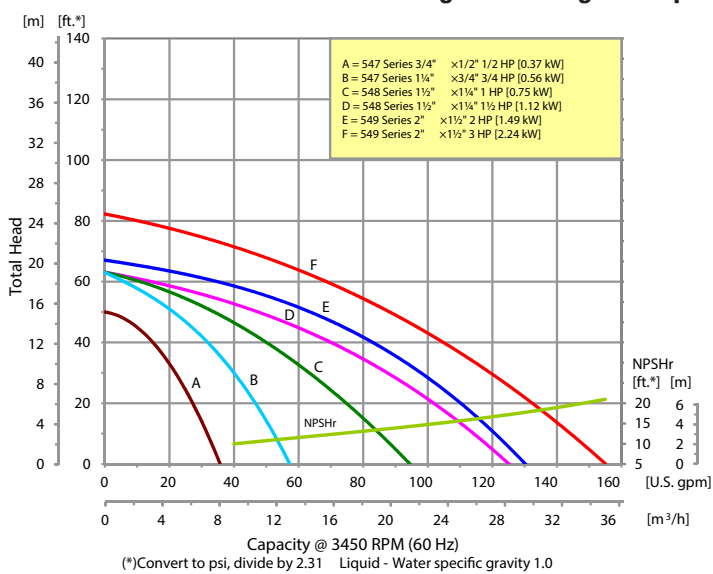

Pumps are designed to handle liquids with solids content or dissolved solids and debris.

# Stainless Steel Straight Centrifugal Pumps

## High Volume Pump Dimensional & Specification Data

Model	Curve	HP	PH	ENC	Voltage @ 60 Hz+	Full Load Amps	SUC*	DIS*	A**	B**	C**	D	E	F	L**	W	H	Ship Wt. (Lbs.)
5475-98	A	1/2	1	ODP	115/230	8/4	3/4	1/2	N/A	5.1 [13.0]	6.4 [16.3]	N/A	2.1 [5.5]	4.1 [10.5]	12.7 [32.2]	8.2 [20.8]	7.8 [14.6]	23
5471-98	B	3/4	1	TEFC	115/230	9/5	1 1/4	3/4	5.4 [13.8]	5.1 [13.0]	6.4 [16.3]	N/A	2.1 [5.5]	4.1 [10.5]	13.7 [34.8]	10.2 [26.0]	7.8 [14.6]	38
5473-98					230/460	3/2			5.4 [13.8]	N/A	6.4 [16.3]	N/A	2.1 [5.5]	4.1 [10.5]	13.2 [33.5]	10.2 [26.0]	7.8 [14.6]	31
5481-98	C	1	3	TEFC	115/230	12/6	1 1/2	1 1/4	5.4 [13.8]	5.1 [13.0]	6.0 [15.4]	N/A	1.8 [4.6]	4.0 [10.2]	13.6 [34.5]	10.6 [26.9]	7.8 [14.6]	40
5483-98					230/460	4/2			5.4 [13.8]	N/A	6.0 [15.4]	N/A	1.8 [4.6]	4.0 [10.2]	12.2 [30.1]	10.6 [26.9]	7.8 [14.6]	35
5485-98	D	1 1/2	1	TEFC	115/230	18/9	1 1/2	1 1/4	5.4 [13.8]	5.1 [13.0]	6.0 [15.4]	N/A	1.8 [4.6]	4.0 [10.2]	14.1 [35.8]	10.6 [26.9]	7.8 [14.6]	49
5487-98					230/460	5/3			5.4 [13.8]	N/A	6.0 [15.4]	N/A	1.8 [4.6]	4.0 [10.2]	13.9 [35.3]	10.6 [26.9]	7.8 [14.6]	38
5491-98	E	2	1	TEFC	115/230	22/11	2	1 1/2	5.4 [13.8]	5.0 [12.7]	6.1 [15.6]	N/A	1.8 [4.6]	4.0 [10.2]	14.9 [37.8]	10.6 [26.9]	7.8 [14.6]	51
5493-98					230/460	6/3			5.4 [13.8]	N/A	6.1 [15.6]	N/A	1.8 [4.6]	4.0 [10.2]	14.5 [36.8]	10.6 [26.9]	7.8 [14.6]	44
5495-98	F	3	1	TEFC	230	16	2	1 1/2	5.4 [13.8]	5.0 [12.7]	6.1 [15.6]	N/A	1.8 [4.6]	4.0 [10.2]	15.4 [39.1]	10.6 [26.9]	7.8 [14.6]	60
5497-98					230/460	8/4			5.4 [13.8]	N/A	6.1 [15.6]	N/A	1.8 [4.6]	4.0 [10.2]	15.0 [38.1]	10.6 [26.9]	7.8 [14.6]	48

(\*) Standard NPT (Female) pipe thread.

Maximum Solids Handling Capacity: 1/8" Diameter

(\*\*) This dimension may vary due to motor manufacturer's specifications.

(+) 3-Phase motors can also operate on 50 Hz. (This will change full load amps, service factor and RPM)

NOTE: Dimensions are in inches (centimeters) and have a tolerance of  $\pm 1/4"$ .

NOTE: Electric supply for ALL motors must be within  $\pm 10\%$  of nameplate voltage rating (e.g. 230V  $\pm 10\%$  = 207 to 253).

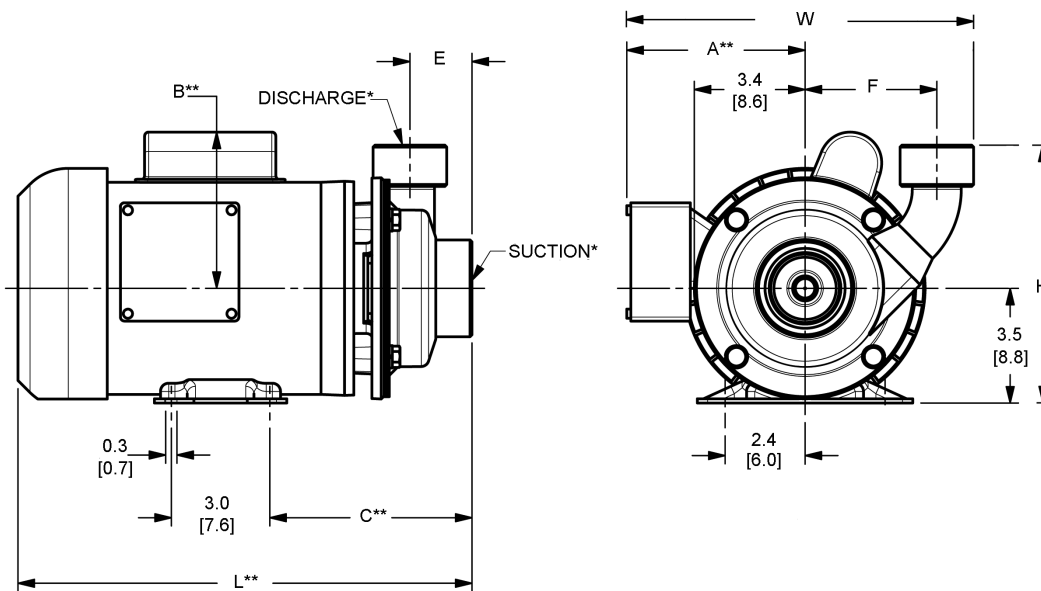

## Standard Features

- Stainless Steel Construction
- Viton® Mechanical Seal and O-ring, Optional Buna-N Seal and O-ring Available
- Investment Cast Stainless Steel Impeller
- Cast Iron Motor Adapter Provides Rigid Mounting
- AeroSpace Fusion Welding
- Stainless Steel Motor Shaft & Hardware
- 1/2 to 3 HP NEMA 56J TEFC Single & Three Phase Motors
- NEMA Base Mounted Motors
- Maximum Working Pressure 150 PSI
- Maximum Temperature 200° F
- QSP – Quick Ship Pump for Many Models

**Hazardous Duty/Explosion Proof motors available from stock ranging from 1 to 10 HP; CALL FOR QUOTATION & LEAD TIME!**